

ORWAK 3500

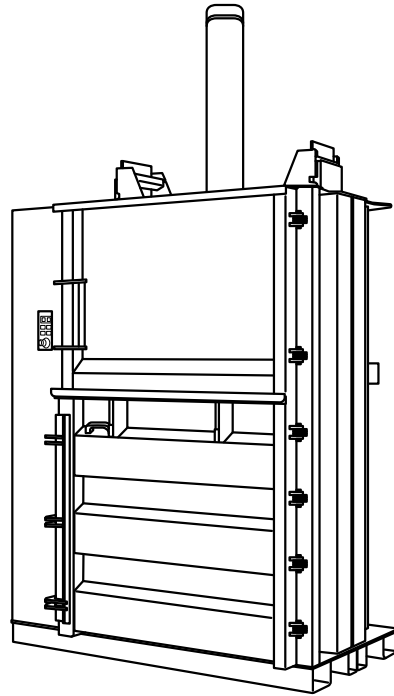



ORIGINAL OPERATING INSTRUCTIONS

English

CONTENTS

Safety information.....	4
Parts of the machine.....	5
Safety.....	6
Control panel	7
Operating instruction.....	8
Weekly inspection and maintenance	10
Technical specification....	12
Dimensional drawing.....	12
Transport	12
CE.....	13
Installation	14
Hydraulic diagram	
Electrical diagram	

IDENTIFICATION

	Svetsaregatan 4 576 33 Sävsjö Sweden	
Type *	Date	
Product No * * *	Weight	
Serial No **		
V ~ Hz		
kW	A	
+40 °C		
+5 °C		
-10 °C **		



- * - XXXX (ex Compactor 3500)
- ** - XXXXXX (ex 121001)
- *** - 490XXXX - XX (ex 4903500-100)

You find the serial number on the baler.
For any inquiries, please indicate the type and
serial number of the baler.

English

OPERATOR WARNING & DUTY

- This manual must be available permanently near the baler.
- Each operator must read and follow the full instruction of this manual before being authorize.
- All operator must absolutely study and fully understand the operator's manual, specifically pay a particular attention to the safety procedure section.
- In case of misunderstanding or doubt, do not start the machine. Contact support service.

Operators and service staff must comply by wearing personal protective equipment (PPE) before using or performing any maintenance operation following rule and regulation code.



Operator and service personal must be trained during the commissioning on the baler operation, by a duly authorized person from the manufacturer.

To avoid any mistake or accident, all operators must understand the operator manual.



All operators must absolutely study and fully understand the operator's manual. This manual must remain available for any personal involve with the baler.

SAFETY SIGN - In the manual



Warning !



The main power switch must be turned off to « 0 » and secured with a padlock.



Do not flush water on the baler.

SAFETY SIGN - On the baler



Danger High Voltage

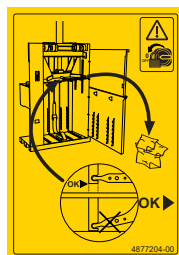

The main power switch must be turned off to « 0 » and secured with a padlock before cleaning.

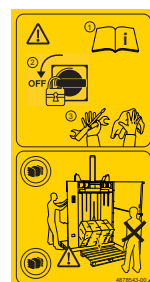

The main power switch must be turned off to « 0 » and secured with a padlock before service or cleaning.

Position yourself to the **SIDE OF** the machine, outside the risk area.
Ensure that no one is in the risk area!

PARTS OF THE MACHINE

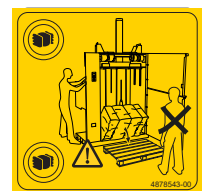
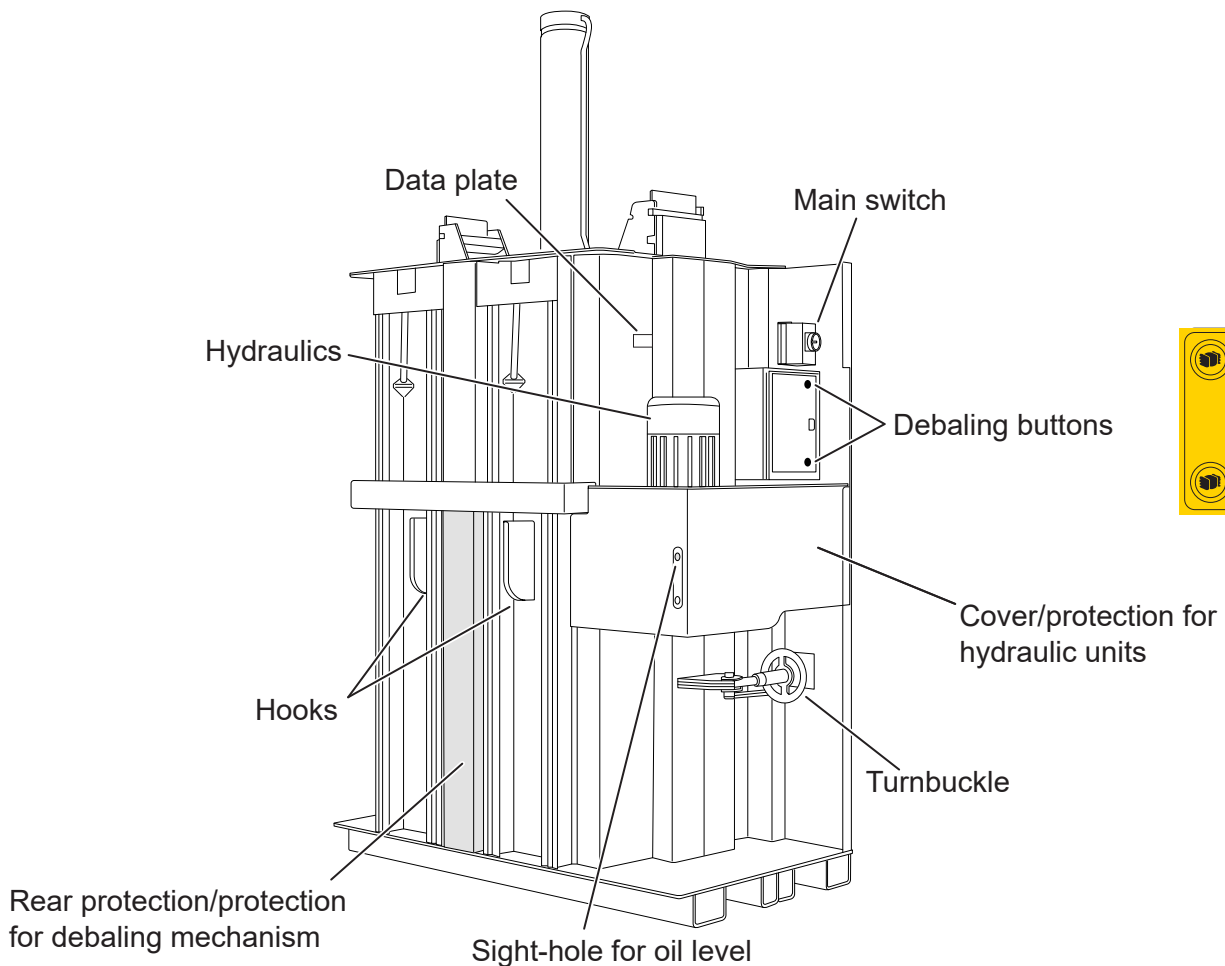
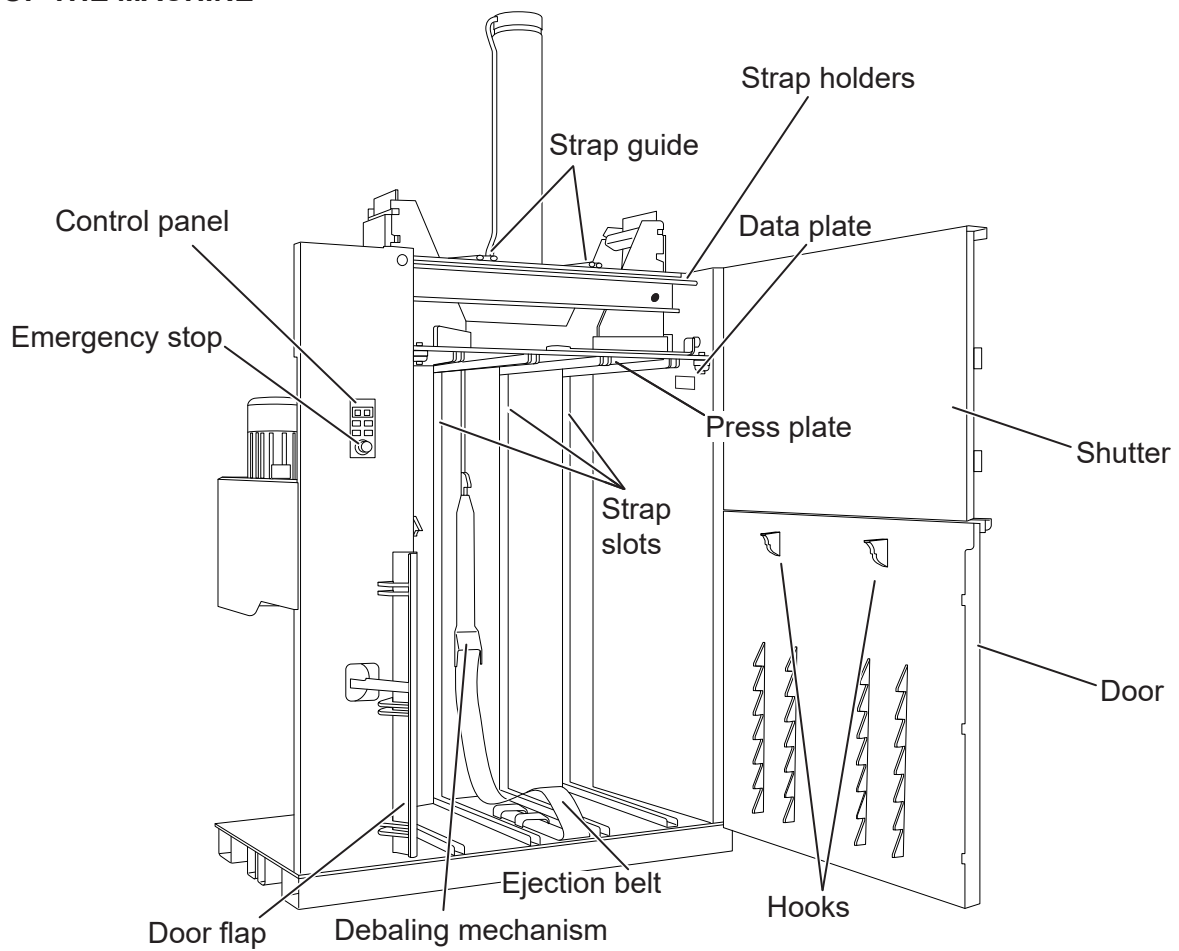

SAFETY

Please read the entire operating instructions **BEFORE** installing and starting the machine. Our Warranty and Product Liability require that:

- that regulations are followed and that no alterations or modifications are made.
- that original spare parts are used, and hydraulic oils and lubricants recommended by the machine manufacturer are used;
- at least one annual service is carried out.

The user is responsible for checking and daily supervision of the machine.

The user is responsible for ensuring that deficiencies are rectified and that the user or other persons are not exposed to danger.

The owner is responsible for ensuring that laws and instructions are followed when working with the machine.



This symbol means **WARNING** or **DANGER** - personal safety instruction!



This machine is designed for **ONE-PERSON OPERATION**.

Only the operator may be in the working area of the machine. The work area is defined under the heading **Technical data; Recommended space for machine in operation**.



The machine must not be used in a public environment but is intended for use in warehouses or the like.



The machine **should not be used if its safety features** (e.g. switches and protection) is disabled, damaged or removed.

Lost or damaged parts must be replaced with **original spare parts**.



The machine may only be operated by those who have **received training and have experience** using it.



The area immediately around the machine and its base must be completely level and suitable for the weight of the machine.



The machine has a **high centre of gravity**. The press plate must be fully lowered when the machine is moved.

Installation, repair and service may **only** be performed by **trained** personnel and in accordance with installation instructions.



The machine may **not** be used by minors.



Never climb on the machine.



Service and repair may only be performed by trained personnel and in accordance with service instructions.



Only authorized personnel may remove covers and protection and then only by turning the main switch to zero. *On the supply side of the main switch, it will never be de-energized!*



When compacting **plastic**, the machine **should** be set to **Plastic** (lower press force), **see the control panel**.



Avoid pressing different hard waste into the machine at the same time (unless the waste is mixed and distributed well in the container, it can cause skewed loading of the press plate with damage to the machine).



The machine contains current-carrying components and must not therefore be placed in an environment where it can be exposed to moisture.



Use the door handle when closing the door. Warning: risk of crushing.



If replacing the incoming cable, a suitable cable must be used. See the spare parts catalogue. The cable must not be spliced.

SAFETY FEATURES

The machine is equipped with the following safety features:

A switch that prevents the machine from being used when the shutter is opened.

Mechanical interlocking doors, as well as covers and doors to protect against dangerous machine movement.

The machine is also equipped with an emergency stop. The safety features referred to above should be checked regularly, see the section on **weekly inspection and maintenance**.

Covers and guards conceal the hydraulics and movable machine parts.

Baling is performed from the side of the machine so that the operator is kept away from the baling area.

RANGE OF APPLICATION

The machine is a hydraulically operated baler designed for compacting **bulky** materials such as cardboard, paper, and plastic. The material being compacted should be evenly distributed in the chamber. Compaction of compact or pre-compacted material may result in damage to the machine. The machine should only be used in areas with a roof, wind protection and normal lighting. The machine is intended for use in the temperature range of -10 ° C to + 40 ° C. At temperatures lower than +5 ° C, a cold-adapted oil must be used.

CONTROL PANEL

Bale lamp – the lamp indicates when it is time to remove the bail from the machine.

CONTROL PANEL

Paper – indicates that the machine is set to compact paper and cardboard. The machine operates using high pressure.

Plastic – indicates that the machine is set to compact plastic. The machine operates using low pressure. See *Technical specifications* for more details. Do not use the “Paper” setting when compacting plastic, as this may damage the machine. If the machine is set to *Plastic* and MAN mode when a compaction cycle is run, the press plate will remain pressed down against the waste for 5 minutes (default).

MAN – indicates that the machine is set to manual start. The start button must be pressed to start a compaction cycle.

AUTO – indicates that the machine is set to automatic start. This means that the machine starts a press cycle when the shutter is closed.

Start – starts a compaction cycle (for manual start).

Temperature warning lamps

Blue lamp – indicates that the machine is cold. The machine may still be operated.
Red light - indicates that the machine is overheated. The machine must **NOT** be operated until it has returned to normal temperature and the lamp has gone out.

Service lamp – see under TROUBLESHOOTING below for more information.

Power lamp – this lamp indicates that there is power to the machine.

Bale size – indicates the selected bale size in five levels. The bale size can be locked. Contact your local distributor for more information

Up arrow – used to raise the press plate to its normal position.

Arrow down – used for lowering the press plate. The press plate will come to a stop **WITH PRESSURE** against the bale in the lower position (e.g. for manual baling).

Emergency stop – used if a compaction cycle has to be stopped immediately.

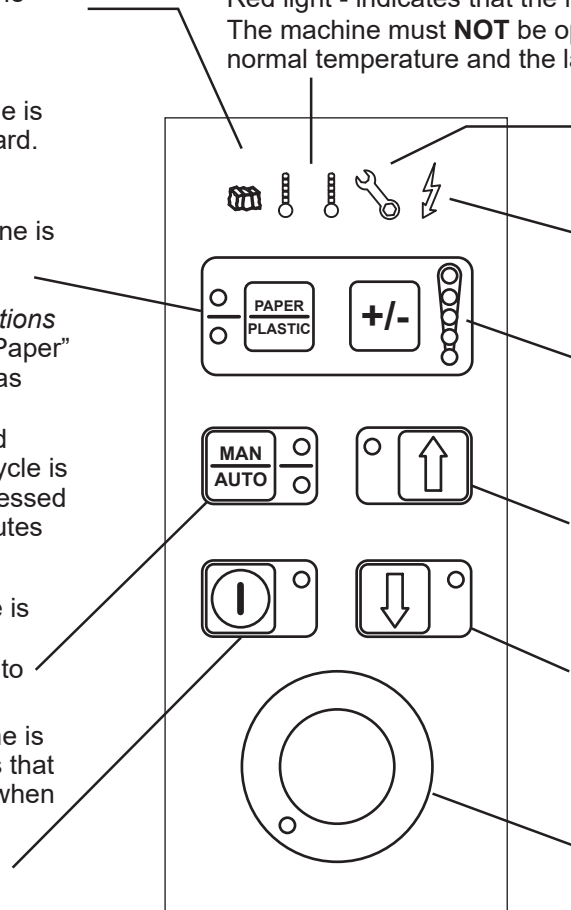

TROUBLESHOOTING

Flashing service light = fault.

Fault messages can be read via the service light.

First try turning on and off with the main power switch and try to restart the machine.



If the fault persists and the service key flashing again don't turn of the power: instead press the emergency stop button, after some seconds there will be a number of flashes, e.g. LED extinguished for 5,10 or 15 seconds followed by 1 to 9 flashes. (Example 5 second 3 flash or 10 seconds 2 flash.)

For optimal service help – mention the flashing message when reporting the fault.

Do not use the machine until an authorised service engineer has corrected the fault.

Service light, steady light = time for servicing. Contact your authorised service engineer.

The machine can continue to be operated.

-  Material of flammable or explosive nature, e.g. pressurized containers or equivalent, which may cause damage, fire, or an explosion when exposed to pressure or sparks, must not be compacted in the machine.
-  Only use straps recommended by the machine manufacturer.
-  Heavily expanding materials, e.g. bubble plastic, must not be compacted in the machine.



ENVIRONMENT AND FIRE

In the event of a fire: put out the burning oil with a carbon dioxide or powder extinguisher. Any fire in the electrical system should be put out with a carbon dioxide extinguisher.

If possible, a binding agent for oil should be stored in the immediate vicinity of the machine, and the machine should not be installed directly over or close to drains.

English

OPERATING INSTRUCTIONS operating procedure – manual start

  →  = 4872304-00 (VG19HD)

WARNING!

Only the operator is allowed in the machine's working area!

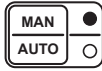

Mounting the strap

Open the shutter. Then open the door by first opening the flap with the turnbuckle.

- 1 Place the strap rolls on the strap holders and set the strap holders in the machine.
- 2 Insert the bale strap in the pipes for straps.
- 3 Pull the straps into the chamber.
- 4 Attach the straps with a loop hooked securely to the bottom edge.
- 5 Using the strap hook, place the bale straps in the strap slots.
- 6 Check that the straps are in the strap slots.
- 7 Use the door handle to close the door. Fasten the flap shut with the turnbuckle.

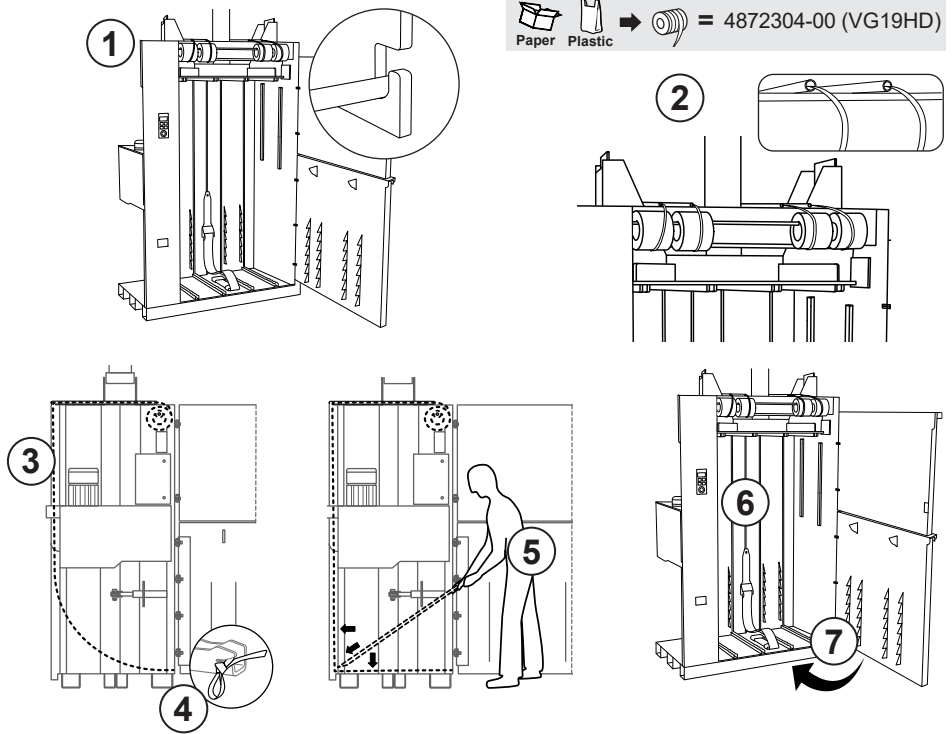

Compaction

For a better baling result, place a large piece of cardboard/flattened cardboard box in the bottom of the chamber.

- 8 Place the waste evenly distributed in the container.
- 9 Close the shutter.
- 10 Press the start button (green). The machine performs a press cycle.

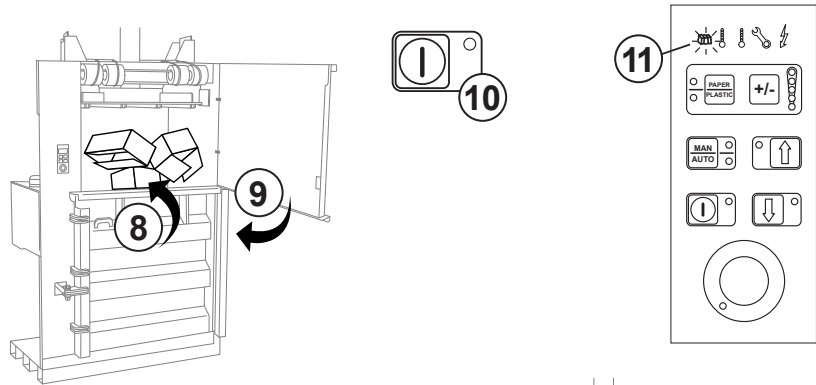

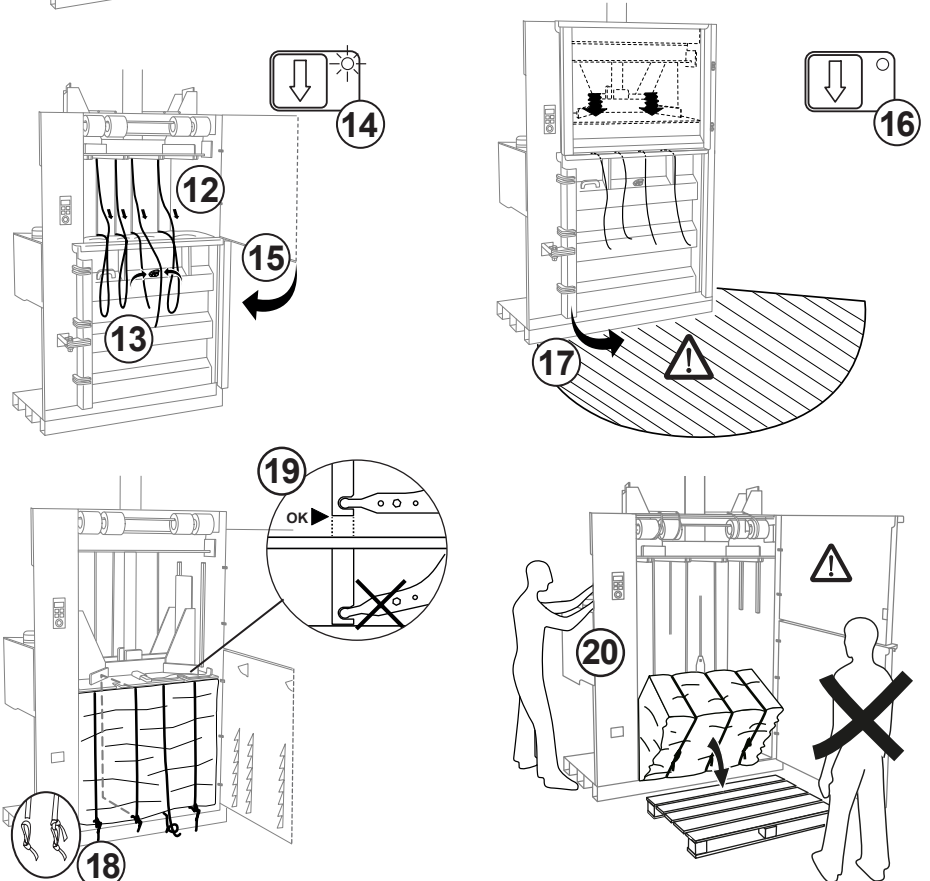

Baling (full bale)

- 11 The bale lamp flashes yellow when the bale is ready – it is time to remove the bale.
- 12 For a better baling result, place a large piece of cardboard/flattened cardboard box on top of the bale. Then pull the straps forward over the bale.
- 13 Use the knife to cut the bale straps.
- 14 Arrow down is flashing – press in the arrow down button to sign off the straps as pulled forward.
- 15 Close the shutter.
- 16 Press the down arrow. The press plate lowers and stops pressed against the waste.
- 17 **Ensure that no one is in the risk area!** Open the shutter and door fully.
- 18 Tie the straps. Place a pallet in front of the machine. **Make sure that no one is in the risk area (in front of the machine).**
- 19 Check that the end of the push rod on the press plate top ends at the OK arrow.
- 20 Position yourself to the SIDE OF the machine, outside the risk area. Press both baling push buttons at the same time. The press plate will rise and the bale will fall out. Start again from step 3.



OPERATING INSTRUCTIONS operating procedure – automatic start

  →  = 4872304-00 (VG19HD)

WARNING!

Only the operator is allowed in the machine's working area!

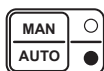

Mounting the strap

Open the shutter. Then open the door by first opening the flap with the turnbuckle.

- 1 Place the strap rolls on the strap holders and set the strap holders in the machine.
- 2 Insert the bale strap in the pipes for straps.
- 3 Pull the baling straps into the chamber.
- 4 Attach the bale straps with a loop hooked securely to the bottom edge.
- 5 Using the strap hook, place the bale straps in the strap slots.
- 6 Check that the straps are in the strap slots.
- 7 Use the door handle to close the door. Fasten the flap shut with the turnbuckle.

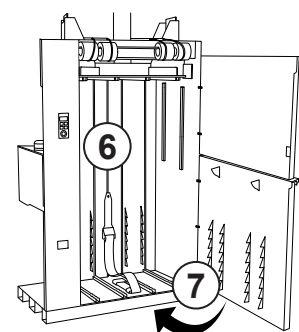
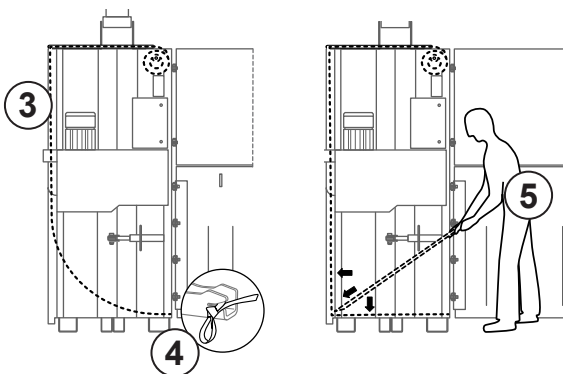
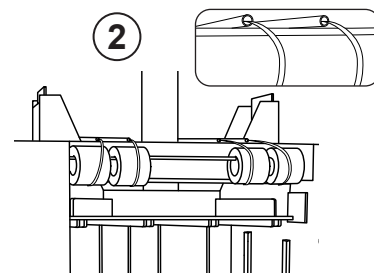
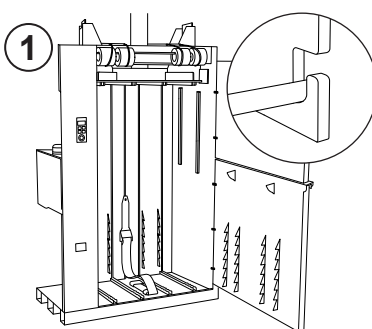

Compaction

For a better baling result, place a large piece of cardboard/flattened cardboard box in the bottom of the chamber.

- 8 Place the waste evenly distributed in the container.
- 9 Close the shutter. The machine will perform a compaction cycle.

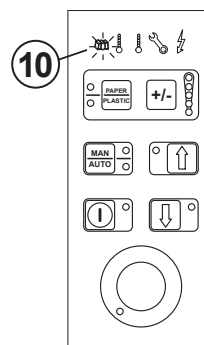
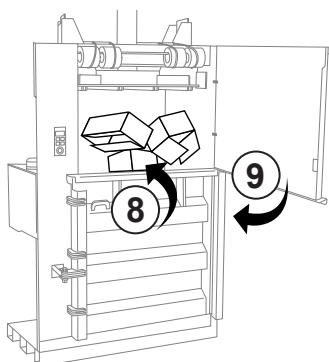

Baling (full bale)

- 10 The bale lamp flashes yellow when the bale is ready – it is time to remove the bale.
- 11 For a better baling result, place a large piece of cardboard/flattened cardboard box on top of the bale. Then pull the straps forward over the bale.
- 12 Use the knife to cut the bale straps.
- 13 Arrow down is flashing – press in the arrow down button to sign off the straps as pulled forward.
- 14 Close the shutter.
- 15 The press plate lowers and stops pressed against the waste.

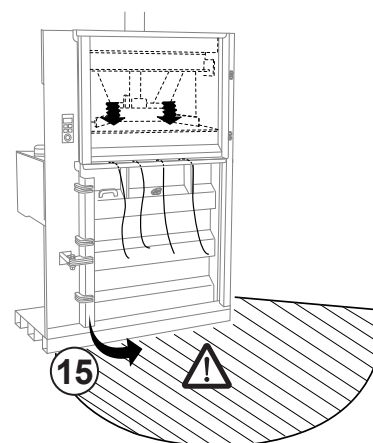
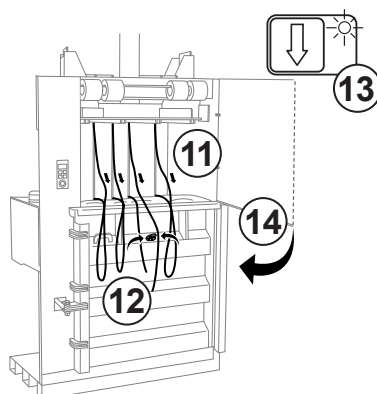

Ensure that no one is in the risk area!
Open the shutter and door fully.

- 16 Tie the straps.
- 17 Check that the end of the push rod on the press plate top ends at the OK arrow.
- 18 Position yourself to the SIDE OF the machine, outside the risk area. Press and hold both baling push buttons at the same time. The press plate will rise and the bale will fall out.

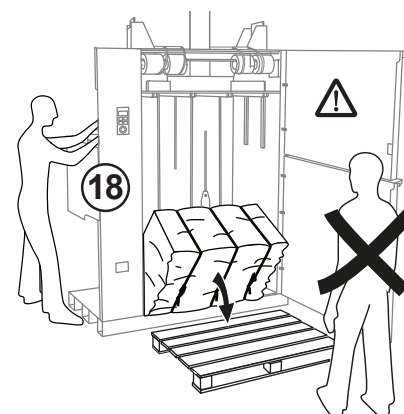
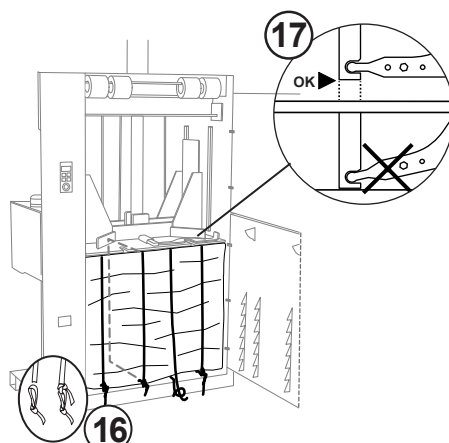

Start again from step 3.

English

WEEKLY INSPECTION AND MAINTENANCE

NOTE! During inspection and maintenance, servicing and the removal of trapped waste, etc:

1. Always turn the main switch to "0" and secure it with a padlock.
2. Do **not** work inside the machine.

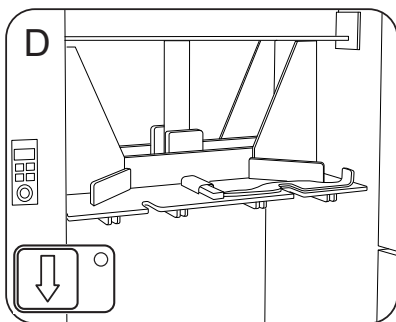
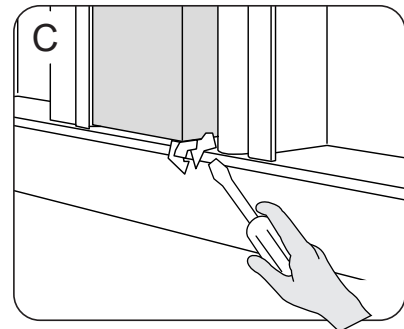
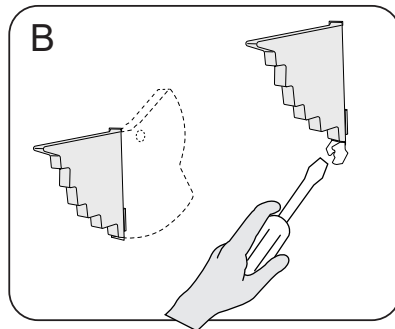
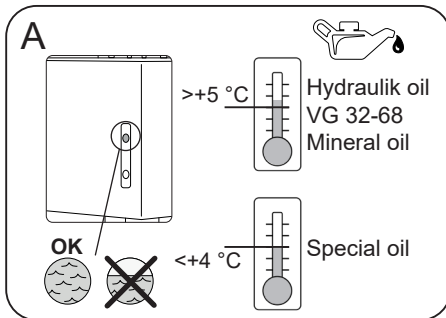
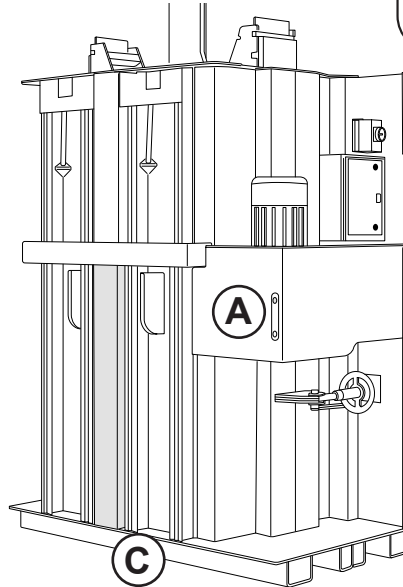
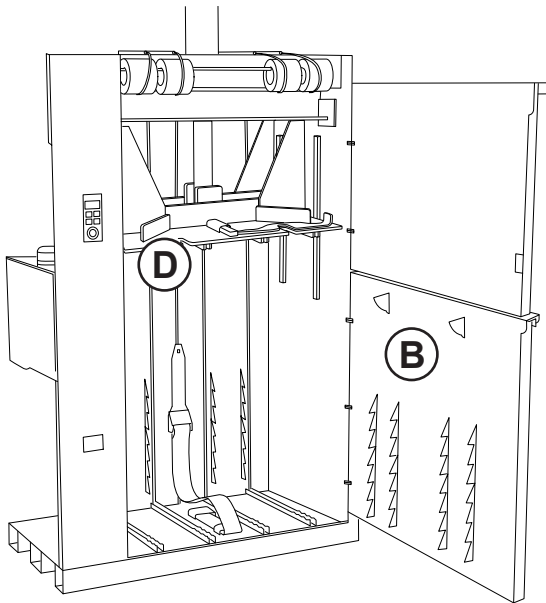
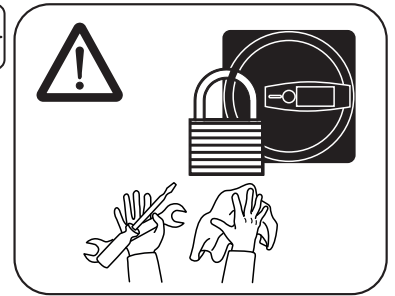
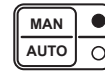

CLEANING

NOTE! The main switch should be in position 0.

Check the oil level (A).

Clean around the latches (B) and behind the cover for the bale ejector device (C).

Remove any waste.

Clean the press plate (D). Make sure that there are no bales in the machine. First lower the press plate using the arrow down button.

Open the door.

Remove any waste. Use the strap hook to gain access to the rear of the press plate.

Use a slightly damp cloth to clean the container and the outside of the machine (E).

Never flush the machine with water.

**SAFETY CHECKS**

- Check the **shutter switch**: it must not be possible to start the machine if the upper shutter is open/opened.
- Check the baling push buttons: it must not be possible to remove the bale from the machine using just one baling push button.
- Check that the **emergency stop** is working.
- Check that all **covers and guards** are intact.
- Check that the machine has no oil leaks.
- Check that no parts are loose or damaged, and that all covers are fitted.
- Check that the power cable is intact and properly protected against impact.

If any fault is found in the functions above, the machine must not be used until it has been repaired by authorised service personnel.

Servicing and repairs may only be carried out by qualified and competent personnel, and in accordance with the machine manufacturer's instructions.

**ANNUAL INSPECTION**

Annual inspection of machinery must be carried out by an authorized service technician, approved by the manufacturer.

**TROUBLESHOOTING**

Flashing service light = fault.

Fault messages can be read via the service light.

First try turning on and off with the main power switch and try to restart the machine.

If the fault persists and the service key flashing again don't turn off the power: instead press the emergency stop button, after some seconds there will be a number of flashes, e.g. LED extinguished for 5, 10 or 15 seconds followed by 1 to 9 flashes. (Example 5 second 3 flash or 10 seconds 2 flash.)

For optimal service help – mention the flashing message when reporting the fault.

Do not use the machine until an authorised service engineer has corrected the fault.

Service light, steady light = time for servicing. Contact your authorised service engineer.

The machine can continue to be operated.



When changing the oil: *Contact the local authorities for guidance regarding the environmentally correct disposal of waste oil.*

Miscibility must be taken into account when changing and/or topping up the oil. The machine comes filled with mineral oil from the factory.

English

TECHNICAL SPECIFICATIONS

GENERAL DATA

Total weight: 2100 kg
Transport height: 2340 (2440) mm

Dimensions:

Height: 3225 mm
Width: 1765 mm
Depth: 1160 mm
Depth with door open: 2410 mm

Recommended space for a machine in operation (work area):

Height: 3300 mm
Width: 2965 mm
Depth with door open: 3560 mm

Loading aperture:

Height: 575 mm
Width: 1240 mm

Bale size:

Height: 1100 mm
Depth: 850 mm
Width: 1240 mm
Weight (paper): up to 500 kg
Weight (plastic): -

Noise level:

<65 (± 1.0) dB (A) (ISO 11200 & 11202)

Paint: Two-part paint and powder coat with phosphatising as base.

ELECTRICAL DATA

Operating voltage: 3x400V, 50Hz

Operating voltage: 5-pin CEE plug (32A)

Electric motor: 7.5 kW

Fuse (delay action): 25A

Protection class: IP 55

HYDRAULIC DATA

Working pressure (paper): 250 bar

Working pressure (plastic): 110 bar

Overload pressure: 270 bar

Press force (paper) 50 tons

Press force (plastic): 22 tons

Surface pressure (paper): 4,84 kg/cm²

Surface pressure (plastic): 2,13 kg/cm²

Cycle time, total: 45 s

Piston stroke: 800 mm

Oil volume: 55 litres

Recommended oil: +5°C to +40°C:

ISO VG 32-68, Mineral oil

Below +5°C

A special oil or heater should be used at lower temperatures.

DIMENSIONAL DRAWING

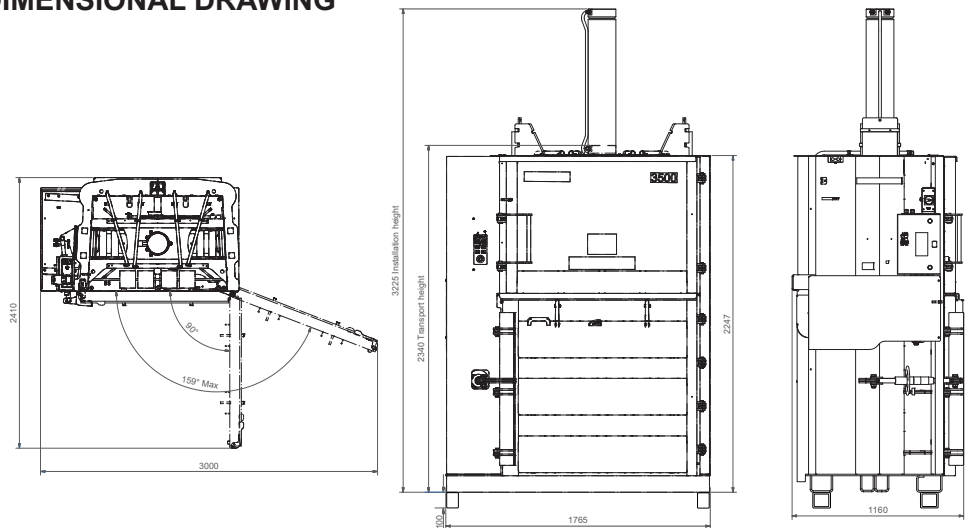

TRANSPORT

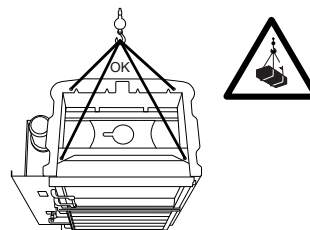
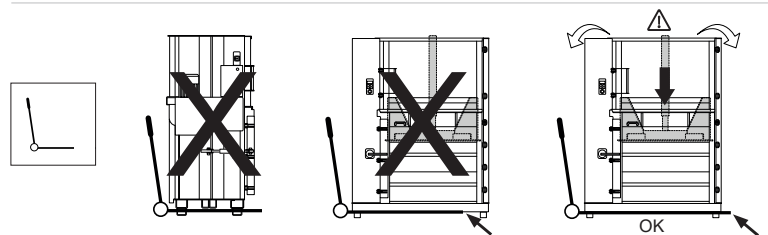
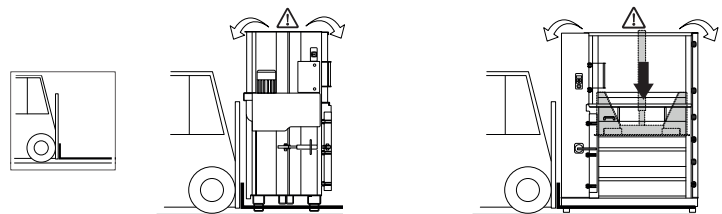
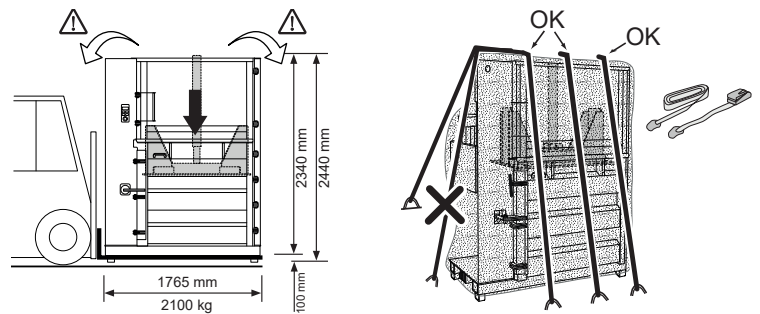

The machine has a high centre of gravity. For shorter movements, the machine's press plate must be lowered to the bottom position. During transport, the press plate with cylinder must be lowered completely.



Shorter moving: Manual machine (MAN): Close the shutter. Press the "Arrow down" on the control panel. Automatic machine (AUTO): In manual mode (MAN), press the control panel. Close the shutter. Press "Down arrow".

For transport: The press plate with cylinder must be lowered completely. This must be done by authorized service technician, approved by the manufacturer.

EC DECLARATION OF CONFORMITY



We Orwak AB
Svetsaregatan 4
SE-576 33 Sävsjö, Sweden
Tel: +46-382-15700

declare under our sole responsibility that the product model

4903500-100 - 4903500-999
4903500-S101 - 4903500-S999

to which this declaration relates is in conformity with the following standards or other normative documents following the provisions of Directives

2006/42/EC (Machinery Directive)
2014/30/EU (EMC Directive)
2011/65/EU (RoHS II)

The machine satisfies the requirements for PL=d and Category 3
in accordance with EN ISO 13849-1

EN 60204-1 (Safety of Machinery – Electrical equipment of machines)
EN 61000-6-1 (EMC Immunity for residential, commercial and light-industrial environments)
EN 61000-6-2 (EMC Immunity for industrial environments)
EN 61000-6-3 (EMC Emission standard for residential, commercial and light-industrial environments)
EN 61000-6-4 (EMC Emission standard for industrial environments)
EN ISO 13849-1 (Safety of Machinery – Safety-related parts of control systems)
EN16500:2014 (Machines for compacting waste materials or recyclable fractions – Vertical baling presses – Safety requirements)

If the product is altered in any way that has not been approved by us,
this declaration of conformity shall no longer be valid.

Sävsjö 28.02.2023

A handwritten signature in blue ink, appearing to read "Philip Karlsson", with a long horizontal stroke extending to the right.

Philip Karlsson

Compiler of technical documentation

English

INSTALLATION

Please read the whole instructions before commencing the installation!

Failure to follow the instructions may result in personal injury.



The installation must be carried out by trained personnel.

Some of the operations involve dangerous machine movement. Take every precaution, as there is a great risk of serious crush injuries.



The machine comes pre-set to MAN (manual) from the factory, and should remain so throughout the entire installation process.



Make sure that no one other than the installation engineer is present in the vicinity of the machine during the installation. Only one person must carry out the installation.



Electrical installation should be carried out by a qualified electrician. The electrician should perform an electrical test on the socket (high-voltage test and insulation test) before the machine is installed and connected.



The ceiling height, the swing radius of the door and sufficient space for servicing, etc. must be taken into account.

1. Transport the machine to the intended installation location.
Lift the machine from **the hydraulic unit side** (see also section **TRANSPORT**)

Note the installation dimensions - the operator must have sufficient space during operation to be able to stand on the left side of the machine when unbalancing.

2. Detach the plastic packaging around the machine as well as any transport packaging.

Open the door and take out the strap, strap holders, strap tool and rubber tiles. Close the door.

3. Unscrew all the nuts (a total of 4) to the transport blocks (key size 19) and remove the nuts.

Carefully lift the machine high enough to remove all transport blocks.

4. Carefully lower the machine onto the rubber tiles.

5. Make sure that the machine is level.

6. Remove the transport boards (under the machine) and their attachments.

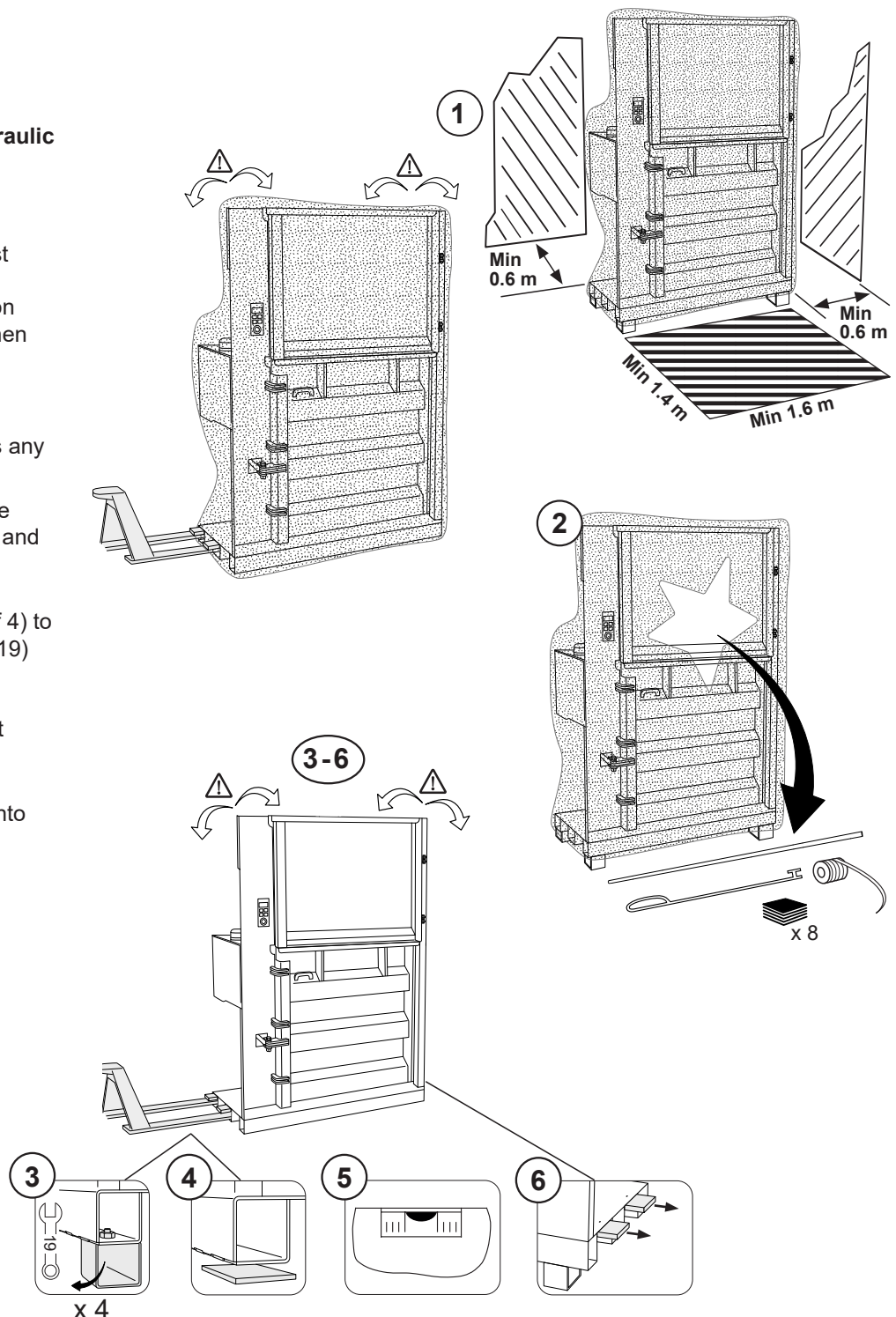

INSTALLATION

RAISE CYLINDER

7. Connect the machine to the wall outlet.
8. Check the direction of rotation of the motor by pressing the arrow up button for about five seconds. If the press plate has not moved upwards, immediately press the emergency stop button, remove the plug, rotate the phases, and try again.
9. Open the upper and lower doors.
10. Remove the screws, washers and nuts from the cylinder.
11. Temporarily swap over the connectors **Y1 and Y2**.
- 12- Raise the cylinder by pressing the bale buttons.
13. Raise the last approx. 150 mm with a jack or truck.
14. **NOTE!** Secure the cylinder with a threaded rod during this step.
15. Securely screw the cylinder into the beam.
16. Swap back the connectors **Y1 and Y2**.

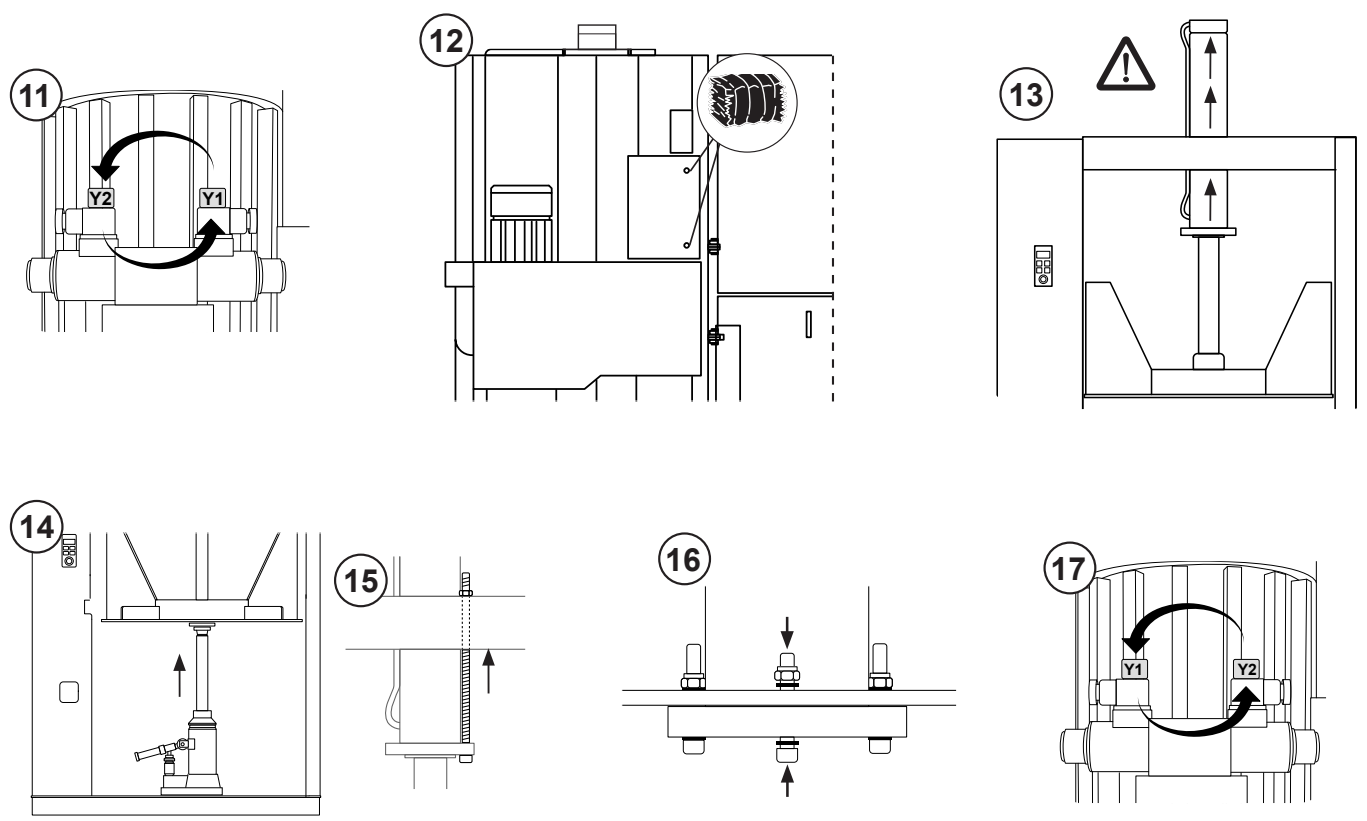
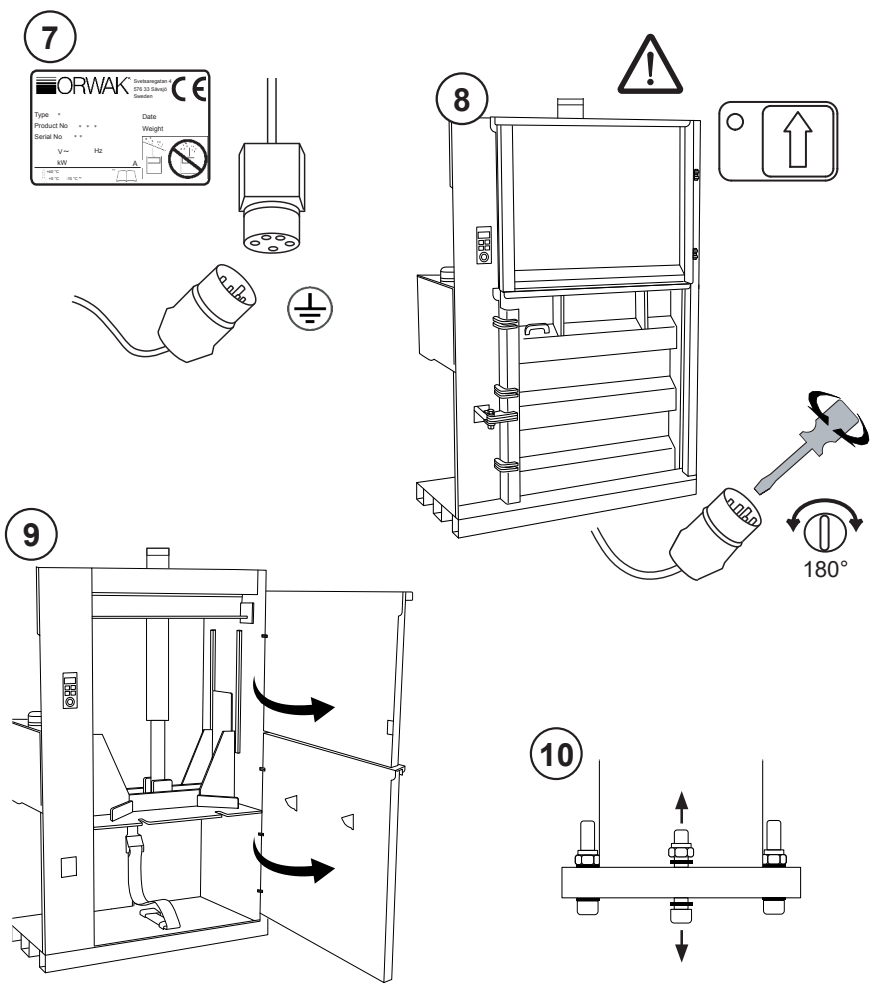

English

INSTALLATION CONTINUATION

18. Remove screw and nut as the press plate rested on underneath transport.
19. Attach the bale donor rod.
20. Screw the cable connector to the sensor.
21. Close door and door. Press the up arrow.
22. Check the oil level when the press plate is in its **uppermost** position. The oil level is visible on the rear side.
23. Place the strap holders and strap rolls in the strap holder supports.

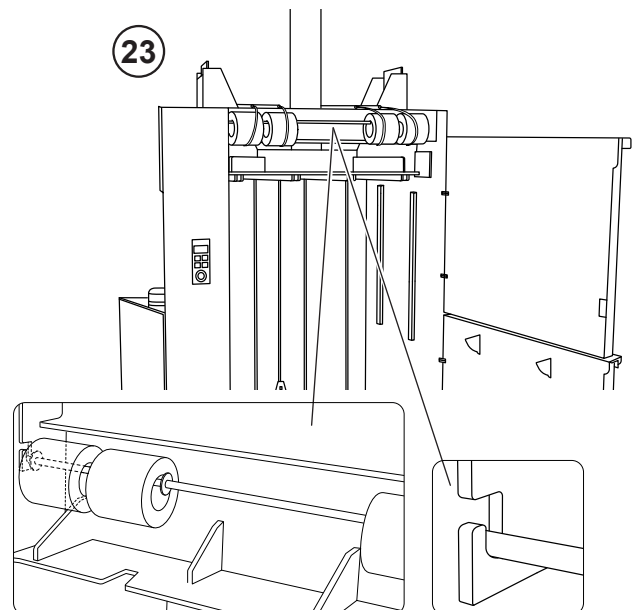
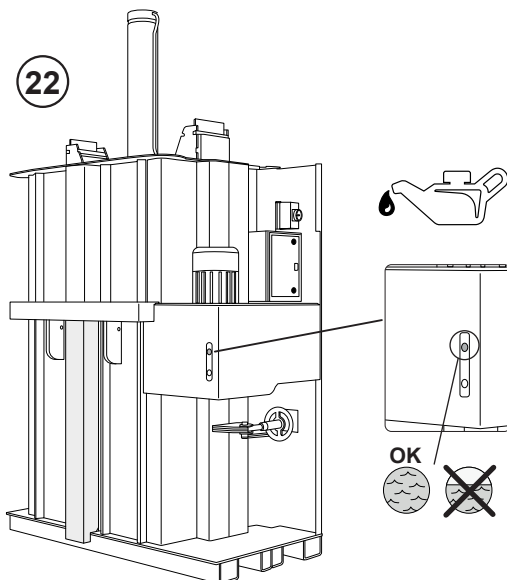
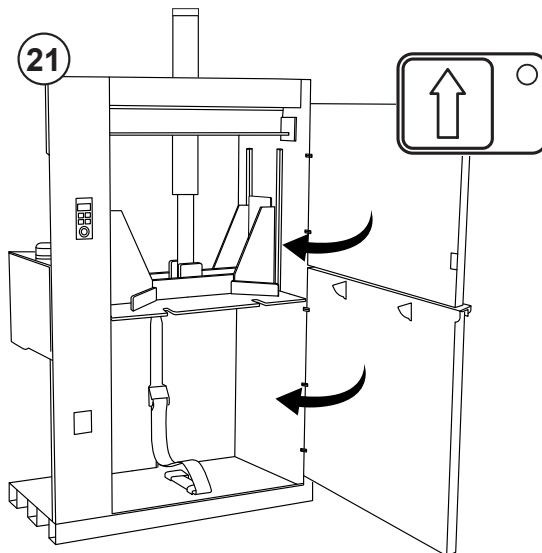
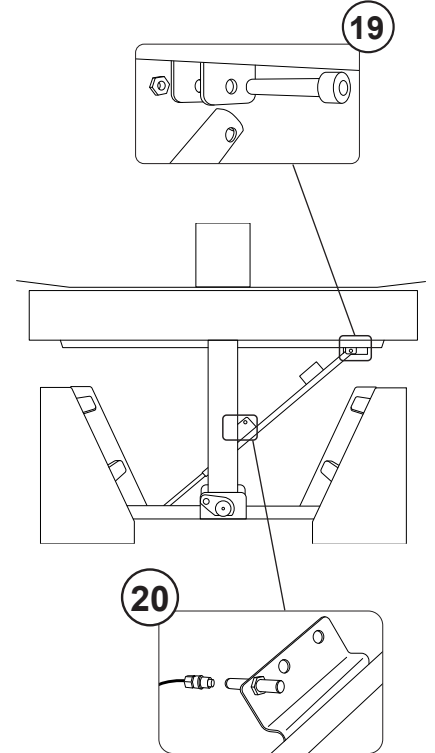
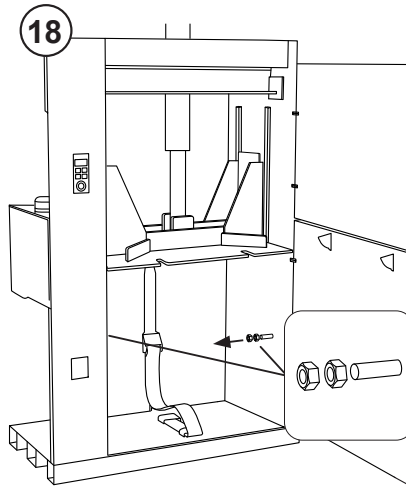

HYDRAULIC DIAGRAM

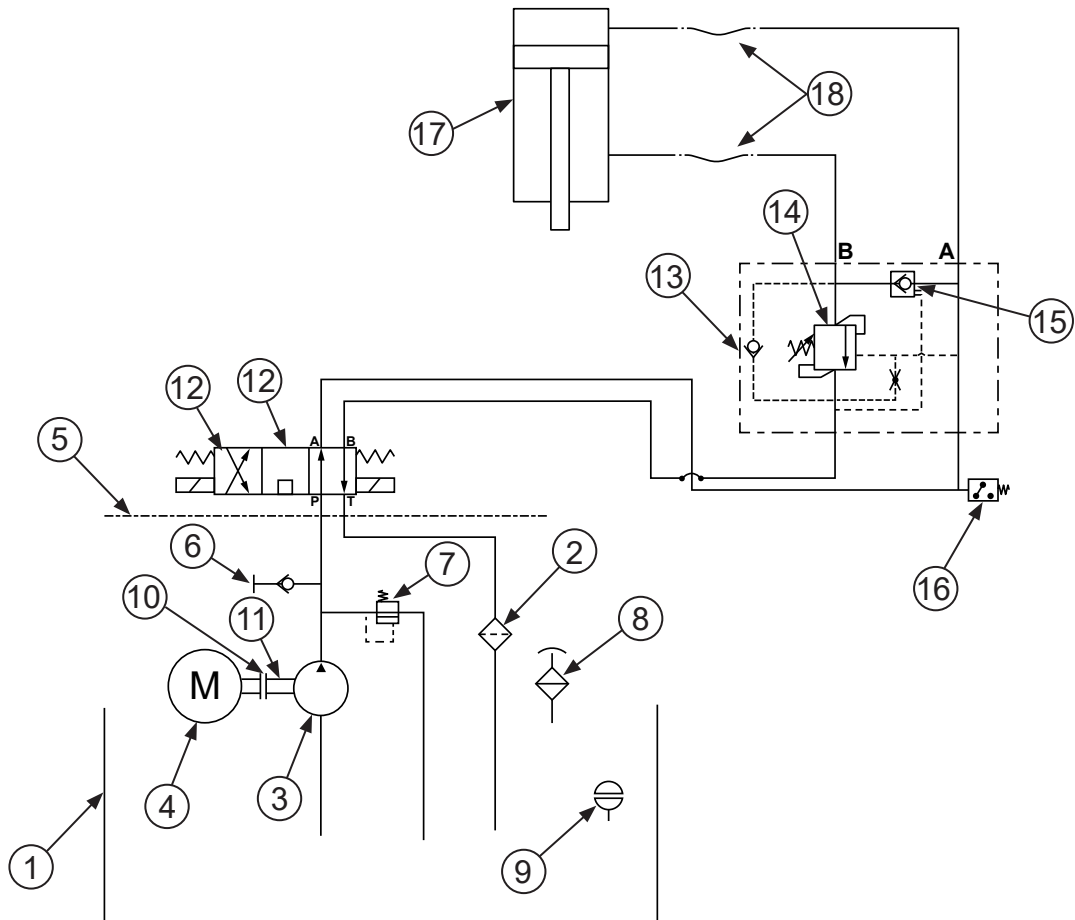

Item no.	English
1	Tank
2	Complete hydraulic filter
2	Hydraulic filter cartridge
3	Hydraulic pump
4	Electric motor
5	Manifold block
6	Test coupling
7	Pressure relief valve
8	Hydraulic filter cap
9	Oil level
10	Pump mount bracket
11	Jaw coupling
12	Directional hydraulic valve
13	Regenerative control valve block
14	Regenerative control valve cartridge
15	Regenerative pilot check valve cartridge
16	Pressure transmitter
17	Hydraulic cylinder
18	Hydraulic hoses

ELECTRICAL WIRING DIAGRAM

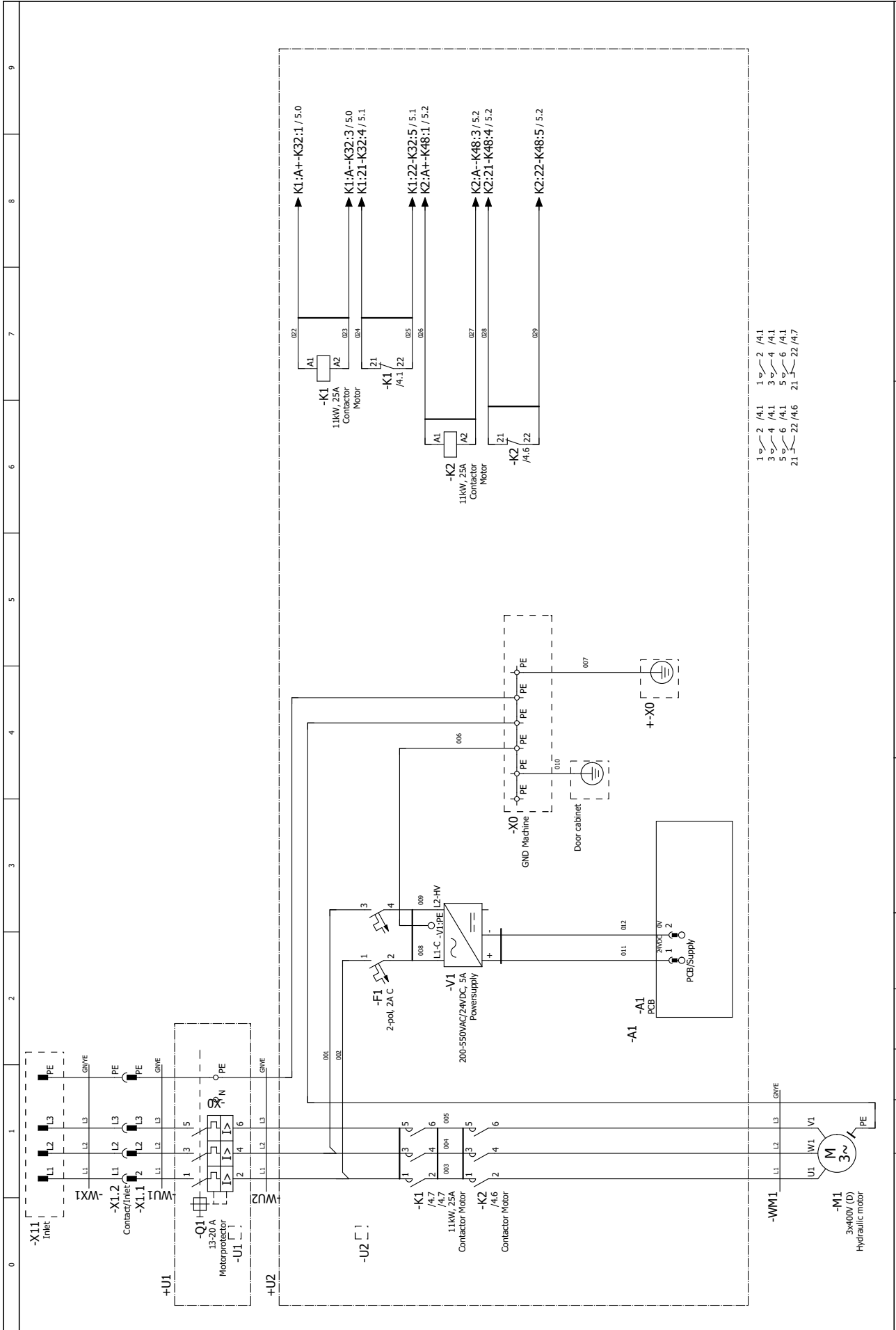

- 1 2 /4.1
- 3 4 /4.1
- 5 6 /4.1
- 21 22 /4.6
- 21 22 /4.7

Revision	Date	Name	Date	2022-02-24	3-Jan-F
				Checked	
				Original	
				Description: 3x400V Included in document:3500	
				Sheet description: Circuit diagram	
				From serial number:	
				Eschema number:	1000269-00
					Sheet 4



ELECTRICAL WIRING DIAGRAM

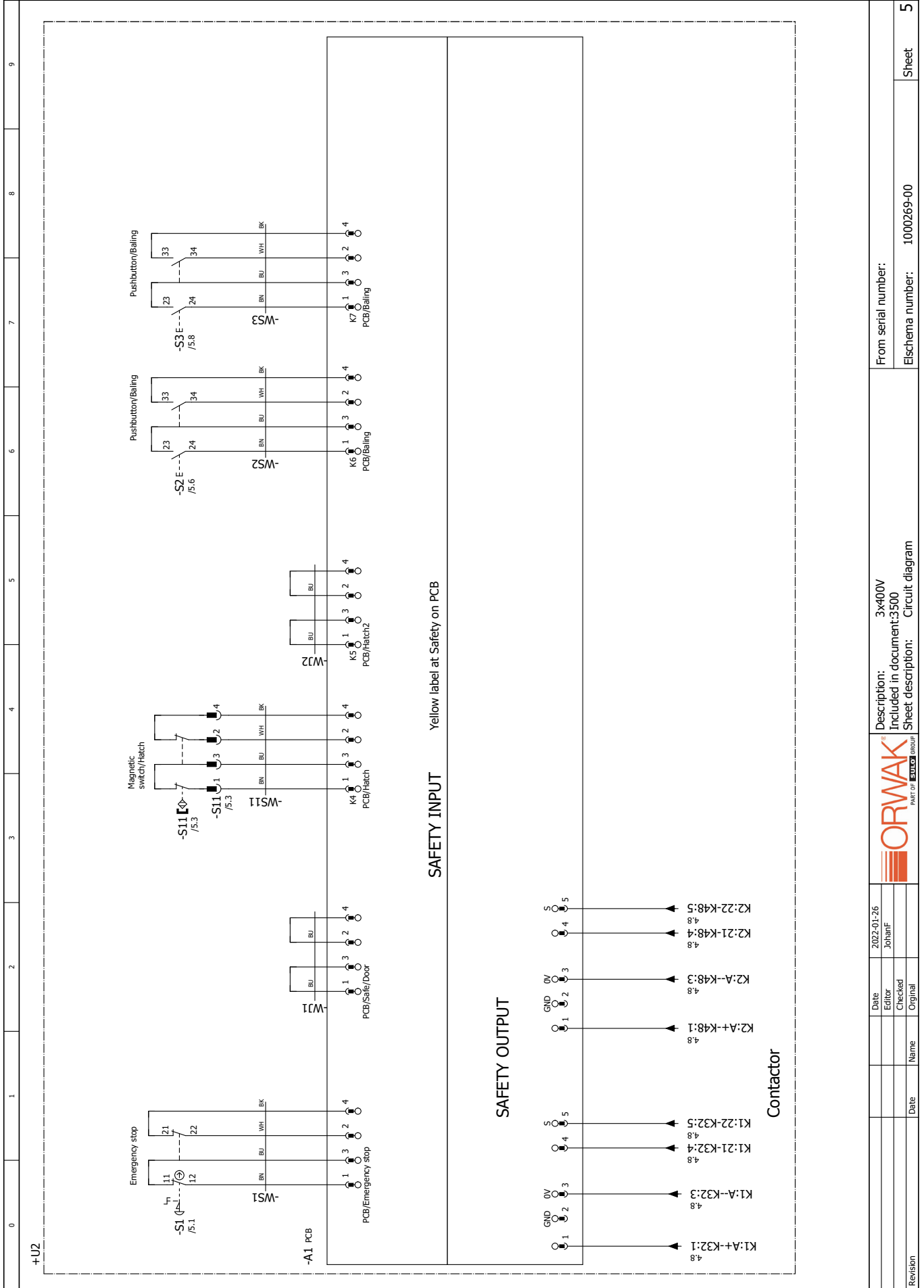

0	1	2	3	4	5	6	7	8	9	
+U2										
SAFETY INPUT Yellow label at Safety on PCB										
SAFETY OUTPUT										
Contactor										
Date	2022-01-26	Date	2022-01-26	Description: 3x400V Included in document:3500						From serial number:
Editor	Johann F	Checked	Original	Sheet description: Circuit diagram						Elschema number: 1000269-00
Revision	Name	Date	Name	Sheet						5

ELECTRICAL WIRING DIAGRAM

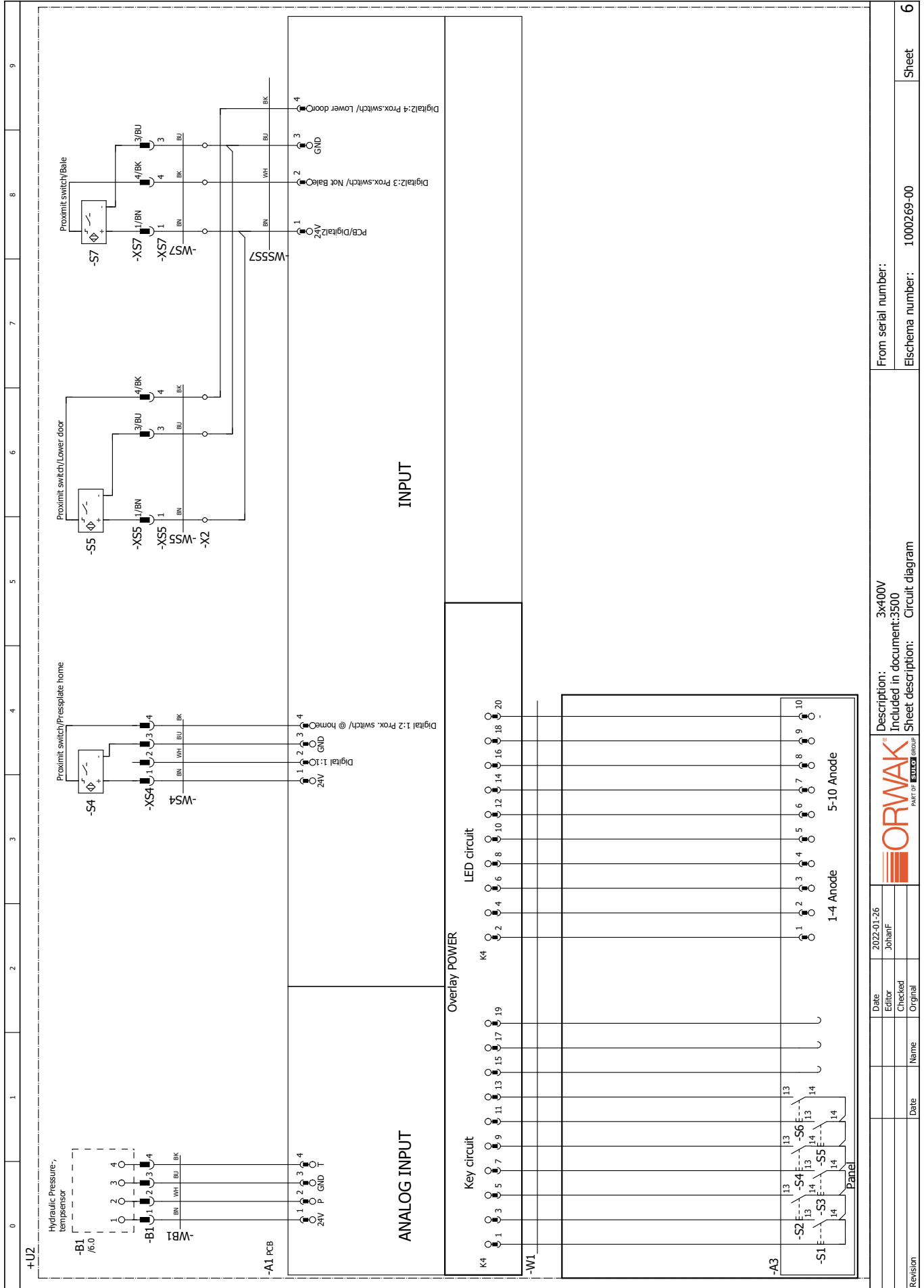

Date	2022-01-26	From serial number:	1000269-00
Editor	Johann	Elcshema number:	1000269-00
Checked			
Original			
Name			
Date			
Revision			
Description: 3x400V Included in document: 3500 Sheet description: Circuit diagram			Sheet
			6

ELECTRICAL WIRING DIAGRAM

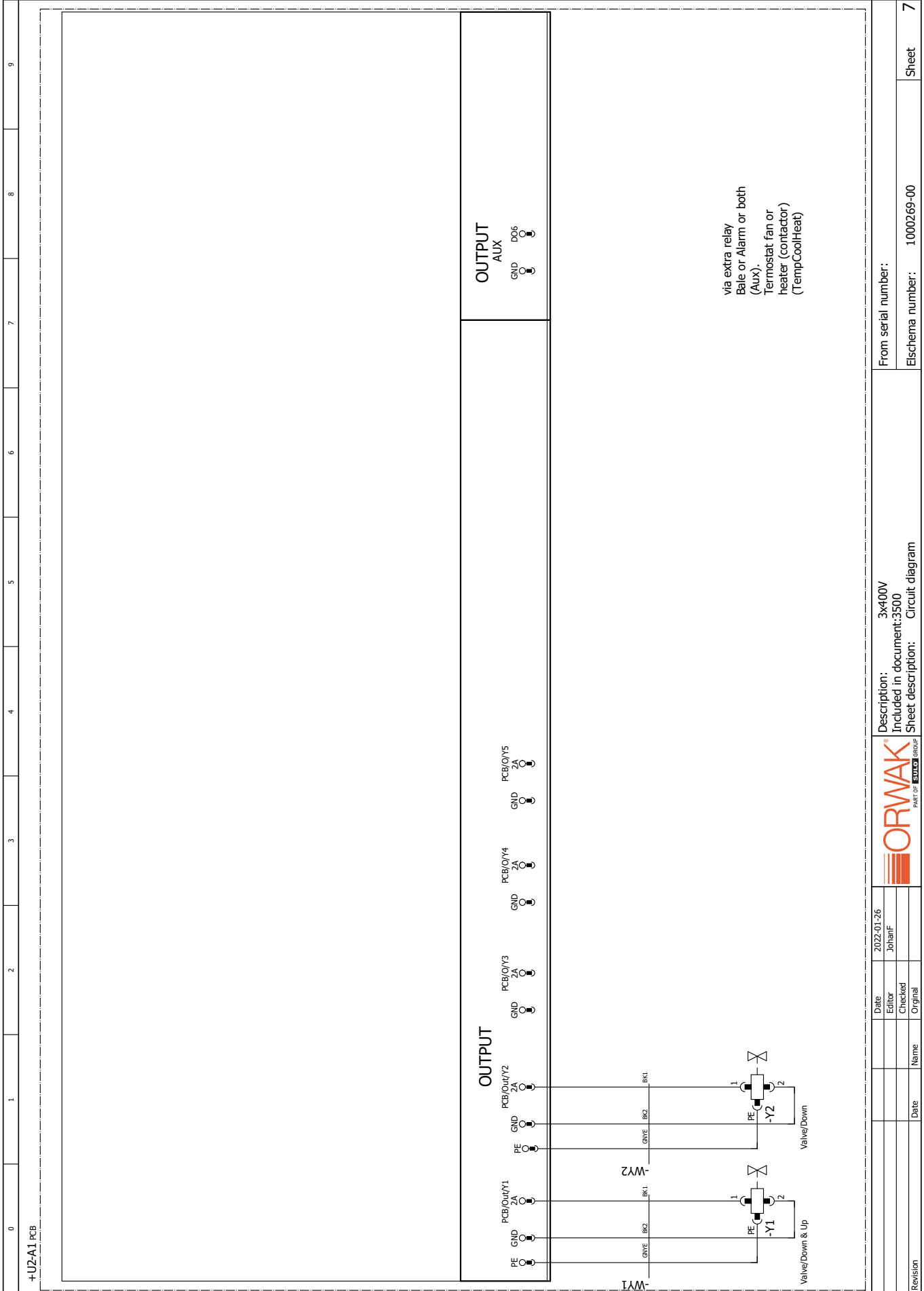

	Description: 3x400V Included in document: 3500 Sheet description: Circuit diagram	From serial number: EIschema number: 1.000269-00	Sheet 7
Date: 2022-01-26 Editor: JohanF Checked: Original:			
Date: _____ Name: _____	Date: _____ Name: _____		
Revision: _____			

COMPACTION SOLUTIONS FOR MOST TYPES OF WASTE

ORWAK develops solutions for sorting and recycling waste materials that improve business efficiency, contribute to a cleaner working and natural environment to provide the best total waste handling economy.

We offer an innovative range of products that promotes sorting at source and make waste management more profitable.

ORWAK AB
Svetsaregatan 4
S-57622 Sävsjö
SWEDEN
Tel: +46-(0)382-15700
info@orwak.com

ORWAK.COM

 **ORWAK**[®]
PART OF **SULO** GROUP